

MP3
PIAGGIO



 **PIAGGIO**®





UNIQUE SENSATIONS

Piaggio has always been synonymous with personal transport which becomes a mass phenomenon.

A revolution which runs through the streets of all of the cities in the world, spanning fashions and generations. A technological innovation which becomes a lifestyle. Today the Piaggio MP3 goes even further, changing the very concept of the "Scooter".

Two front wheels and one rear wheel, for a more enjoyable and safer ride than was ever possible before. A revolutionary chassis which promises all the fun of a two-wheeler, at the same time guaranteeing exceptional stability.

A design made up of soft, wrap-around lines, to achieve new goals in terms of comfort and functionality. The Piaggio MP3 is the new way for you to get around: two wheels ahead of the rest.





THE PIAGGIO MP3 GIVES YOU
THE UNPARALLELED SAFETY OF
ITS THREE WHEELS AND TRIPLE
DISC BRAKES FOR A VERY SHORT
STOPPING DISTANCE, AT
ANY MOMENT AND IN
ANY SITUATION.

3 wheels + 3 disc brakes = **+20% MORE BRAKING POWER**

**GUARANTEED
FUN**

Go out on the Piaggio MP3 and enter a completely new dimension: of sensations and safety. The two front wheels combine the ride dynamics typical of a motorcycle with incredible road holding. The parallelogram suspension system, a Piaggio patented innovation, guarantees unrivalled stability, even on wet or loose tarmac, or trailing other vehicles.

The Piaggio MP3 is also distinguished by exceptional braking performance: thanks to the 3 wheels and 3 powerful 240mm disc brakes with twin piston callipers, allowing record deceleration (around 8 metres per second) and a stopping distance more than 20% shorter than that of normal two-wheeled scooters (even with ABS).



PIAGGIO DESIGNED
AND DEVELOPED THE
PARALLELOGRAM
SUSPENSION SYSTEM TO
PROVIDE EXCEPTIONAL
DYNAMIC STABILITY.



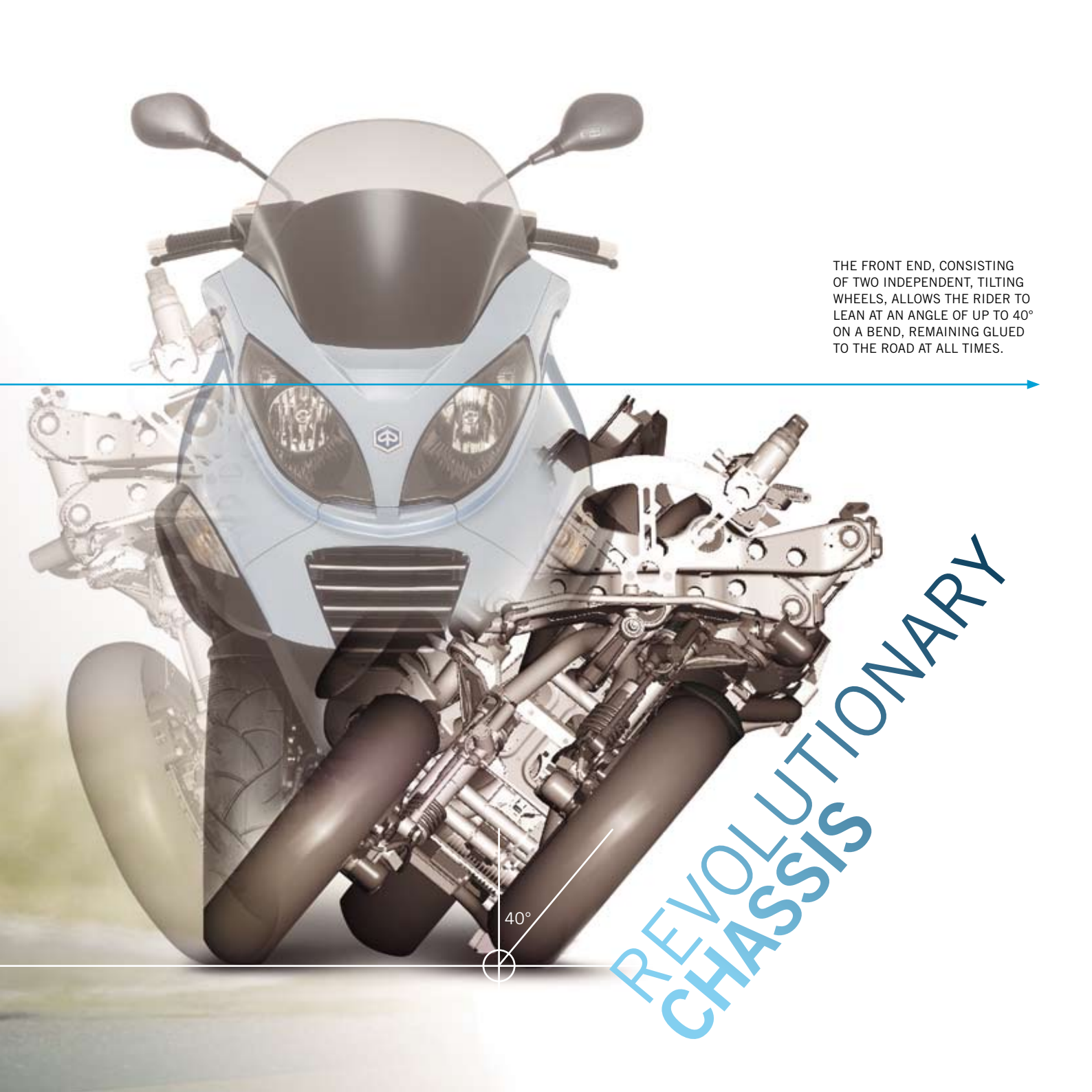

THE FRONT END, CONSISTING OF TWO INDEPENDENT, TILTING WHEELS, ALLOWS THE RIDER TO LEAN AT AN ANGLE OF UP TO 40° ON A BEND, REMAINING GLUED TO THE ROAD AT ALL TIMES.

REVOLUTIONARY
CHASSIS

40°

1. CHARMING FRONT
THE PROTECTIVE WRAP-AROUND LINES OF THE TOP FAIRING AND DOUBLE LIGHT UNIT BLEND WITH THE DESIGN OF THE FRONT FAIRING AND MUDGUARD MADE OF SHOCKPROOF MATERIAL.

4+5. EXCEPTIONAL STORAGE SPACE
ACCESSIBLE BOTH FROM THE REAR HATCH AND FROM UNDER THE SEAT, THE CAPACITY OF THE STORAGE COMPARTMENT IS AN ENORMOUS 65 LITRES, MEANING THAT IT EASILY HOLDS TWO FULL HELMETS OR ITEMS UP TO ONE METRE LONG.



2. COMPLETE INSTRUMENTATION
ELEGANT AND TECHNOLOGICAL, THE DASH SHOWS THE RIDER ALL VEHICLE INFORMATION AT A GLANCE. THE KEY ALSO ACTS AS A REMOTE SEAT OPENER, WHILST FROM THE IGNITION BLOCK YOU CAN OPEN THE FUEL COVER AND THE REAR HATCH.

3. AMAZING ENGINE
FLUID AND FUN PERFORMANCE, LOW CONSUMPTION AND MAXIMUM RESPECT FOR THE ENVIRONMENT, IN TWO HIGH-TECH ENGINES, ALREADY EURO 3 COMPLIANT: PIAGGIO QUASAR 250 AND LEADER 125.

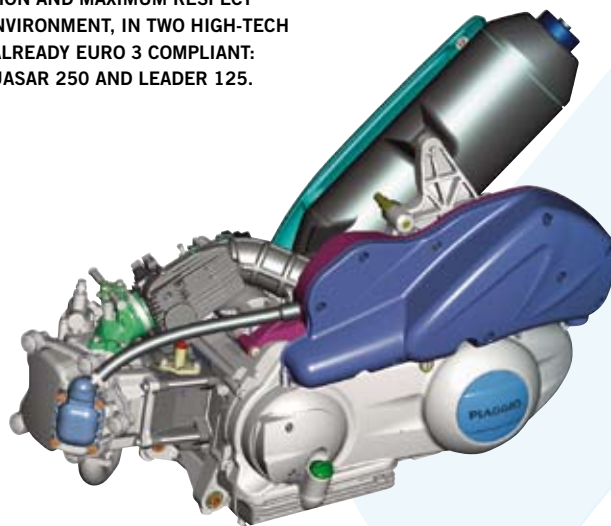

EASY TO PARK

WITH THE PIAGGIO MP3 YOU CAN SAY GOODBYE TO PARKING PROBLEMS. THE SIZE OF A MAXI SCOOTER, IT HAS AN ABSOLUTELY INNOVATIVE FEATURE: THE "ROLL LOCK" ELECTRONIC FRONT SUSPENSION LOCK WHICH ALLOWS IT TO PARK ANYWHERE, EVEN WITHOUT THE STAND PROVIDED. SIMPLY PRESS A BUTTON ON THE HANDLEBAR TO ACTIVATE THE SYSTEM AND THE VEHICLE SAFELY SUPPORTS ITSELF. THE SYSTEM IS DISABLED AUTOMATICALLY WHEN THE VEHICLE BEGINS MOVING OR BY PRESSING THE BUTTON AGAIN. A PRACTICAL LEVER ON THE REAR OF THE FAIRING ALSO ACTIVATES THE PARKING BRAKE SO THAT YOU CAN PARK ON A SLOPE.



EXTRAORDINARY FEATURES

Designed using the most sophisticated CAD programs and rigorously tested at each stage of its development, the Piaggio MP3 is cutting edge in all of its details. The high-strength tubular steel frame guarantees the best stability and distribution of weight, in perfect harmony with the engine and suspensions.

The dimensions and proportions are similar to those of a traditional scooter, with even a small front end. Developed in the wind tunnel, the bodywork combines a revolutionary look with dual functions: maximum protection for the rider at the front, comfort and exceptional storage capacity at the back.

Quick and safe, the Piaggio MP3 darts in and out of city traffic as if it's quite at home: it negotiates cobbles, rails and drain covers with unbeatable safety and stability. The seat, with integrated backrest and special ergonomic shape, is very comfortable and suits riders of all sizes, whilst its height from the ground promotes manoeuvrability and control in all situations. There is also comfort and protection for the passenger, thanks to the side handles for a perfect grip.

Piaggio MP3 is extraordinary in every way, including its accessories; from the “winter pack” with the comfort windshield, the special winter tyres, the heated leg cover and waistcoat, to the Tom Tom Rider GPS navigator with its 3,5” LCD monitor, the X-Jet helmet complete with a Bluetooth communication system, the electronic anti-theft device with remote and other great ideas. Actually, they are revolutionary: just like your **Piaggio MP3**.



COMFORT WINDSHIELD
WITH HAND GUARDS,
OFFERS THE RIDER TOTAL
PROTECTION
IN COMPLETE SAFETY.

HEATED LEG COVERS
BATTERY-POWERED, THESE
CREATE AN IDEAL MICRO-CLIMATE
WHICH IS VERY COMFORTABLE
EVEN AT THE HARSHTEST
TEMPERATURES.

WINTER TYRES
MADE FROM A SPECIAL THERMAL
MIX WHICH GUARANTEES
MAXIMUM GRIP DURING THE
WINTER MONTHS.

TOM TOM RIDER
SAT NAV SPECIFICALLY FOR
MOTORCYCLES WITH BLUETOOTH
AND 3.5” LCD SCREEN. SUPPLIED
WITH EUROPEAN MAPS.

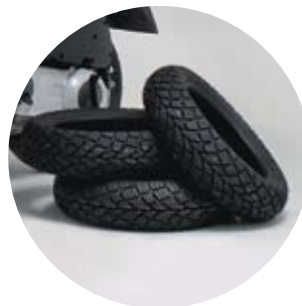

**MP3
OPTIONS**

	MP3 250 ie	MP3 125
Engine	Single-cylinder QUASAR, 4-stroke, 4 valves, electronic injection, catalysed	Single-cylinder, 4-stroke, 4-valve Piaggio LEADER with SAS and two-stage catalytic converter
Cylinder capacity	244.3 cc	124 cc
Bore / stroke	72 mm / 60 mm	57 mm / 48.6 mm
Compression ratio	10.5:1	12.0:1
Max. power at output	22.5 bhp (16.5 Kw) at 8250 rpm	15 bhp (11 Kw) at 9250 rpm
Max. torque	21 Nm at 6750 rpm	12 Nm at 8500 rpm
Cooling	Liquid	Liquid
Gear box	CVT automatic transmission with centrifugal clutch	CVT automatic transmission with centrifugal clutch
Ignition	Inductive ignition controlled by ECU with 3D mapping.	Electronic with capacitive discharge (CDI) and advance mapping.
Carburetion	Indirect single point, closed loop fuel injection system with Lambda sensor and 3 way catalytic converter.	Ø29 CVT carburettor with throttle position sensor
Starting	Electric with torque limiter and automatic decompressor	Electric (Bendix) with automatic decompressor and automatic choke
Frame	High-strength tubular steel twin cradle	High-strength tubular steel twin cradle
Front suspension	Parallelogram consisting of four aluminium arms supporting two steering tubes, cantilever suspension system – Travel: 85 mm	Parallelogram consisting of four aluminium arms supporting two steering tubes, cantilever suspension system – Travel: 85 mm
Rear suspension	Two double-acting hydraulic shocks and adjustable spring preload – Travel: 110 mm	Two double-acting hydraulic shocks and adjustable spring preload – Travel: 110 mm
Front brake (both models)	Two Ø 240 mm stainless steel discs and floating calliper with two pistons Ø 30 mm	Two Ø 240 mm stainless steel discs and floating calliper with two pistons Ø 30 mm
Rear brake	Ø 240 mm stainless steel disc and calliper with Ø 30 mm opposed pistons	Ø 240 mm stainless steel disc and calliper with Ø 30 mm opposed pistons
Front wheel rim	Die cast aluminium alloy 12" x 3.00	Die cast aluminium alloy 12" x 3.00
Rear wheel rim	Die cast aluminium alloy 12" x 3.50	Die cast aluminium alloy 12" x 3.50
Front tyre	Tubeless 120/70-12" 51P	Tubeless 120/70-12" 51P
Rear tyre	Tubeless 130/70-12" 62P	Tubeless 130/70-12" 62P
Length/Width	2130 mm / 745 mm	2130 mm / 745 mm
Height	1490 mm	1490 mm
Seat height	780 mm	780 mm
Dry weight	204 kg	199 kg
Fuel capacity	12 litres (including 1.8 litre reserve)	12 litres (including 1.8 litre reserve)



SKY BLUE



EXCALIBUR SILVER



RUBY RED



GRAPHITE BLACK

Piaggio suggests



The Trademark

PIAGGIO[®] is the property of

PIAGGIO & C.s.p.a.

For prices and to locate your nearest dealer FREEPHONE 00800 818 29800
quoting reference MK2. Visit our web site at www.uk.piaggio.com

Colours and specifications are correct at time of publishing (November 2006) but are subject to change at any time, without notice. Please check latest specification and colour availability with your dealer before you order

PIAGGIOASSIST

ROADSIDE ASSISTANCE

Twelve months roadside recovery and home start on all scooters over 50cc.

PIAGGIOEASY

FINANCIAL SERVICES

All-inclusive customer finance:
contact your dealer for details

PIAGGIOPLUS

INSURANCE SERVICES

Contact your Piaggio dealer or call
0845 601 3095 for an insurance quote

2 YEARS
Warranty

www.uk.piaggio.com

